

European Service Case (WNG-IMPULS)

Deli, cheese, sandwiches and salads

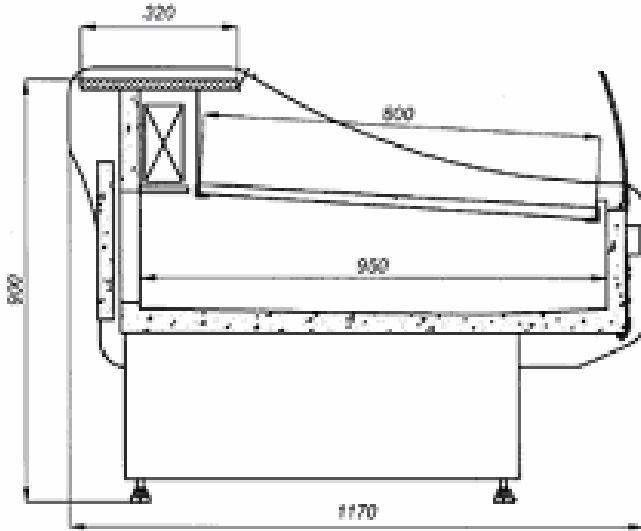

Standard:

- Curved front glass
- Mirror finish interior with SS floor
- Granite back counter
- ABS sides
- Interior lighting
- Temperature control with thermometer
- Automatic defrosting
- Gravity coil system
- Front window defogger
- Double Duty complete with refrigerated bottom storage
- Environment friendly R 507

Technical Data:

Model W	Length (Inch)	Depth (Inch)	Height (Inch)	Capacity (HP)	Voltage / Amps	Weight lbs.
12 NG	49	46	35	1/3	115/8	335
18 NG	73	46	35	1/2	115/16	476
24 NG	94	46	35	2x1/3	115/16	593
30 NG	122	46	35	2x1/2	115/16	778

Optional:

- S/S bottom panel
- Self contained
- Possibility of multiplexing
- Units are available with a divider
- More sizes are available



Atlanta Ltd

133 The West Mall, Unit 9
 Toronto ON M9C 1C2
 416 626 7210

The equipment is designed to operate under normal environmental conditions being below 75°F / 24°C ambient, 55% Relative Humidity.