

# OPEN MERCHANDISER R-M/n/o

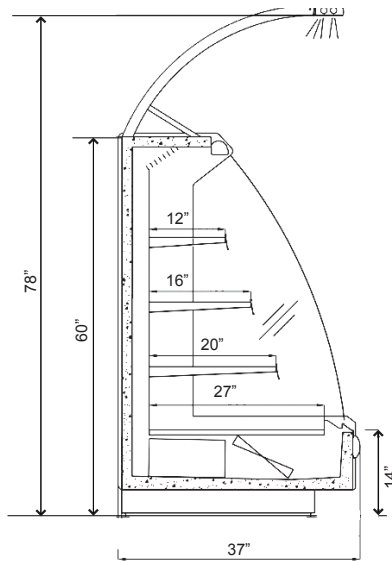

### Packaged Meats, Milk Products, Drinks

MODEL	DIMENSIONS	CAPACITY	REMOTE
R-12M/n/o	L53"x D37"x H60"	1 HP	230V/15A/60Hz
R-18M/n/o	L73"x D37"x H60"	1 HP	230V/15A/60Hz
R-20M/n/o	L83"x D37"x H60"	1 HP	230V/15A/60Hz
R-25M/n/o	L102"x D37"x H60"	2 x 3/4 HP	230V/20A/60Hz

#### Standard:

- Forced-Air refrigeration system
- ABS sides with secured glass
- Roll up front blind for night-time
- Interior lighting
- Adjustable and removable shelves
- SS floor
- Temperature control with thermometer
- Automatic defrosting
- Remote compressor

#### Optional:

- Self contained
- Cases only (no compressor)

#### Environment:

- The equipment is designed to operate under normal environmental conditions being below 75 °F / 24 °C ambient, 55% Relative Humidity.

Sample colour finishing: (silver is the standard colour)

