

## PASTRY CASE: C-PN-W

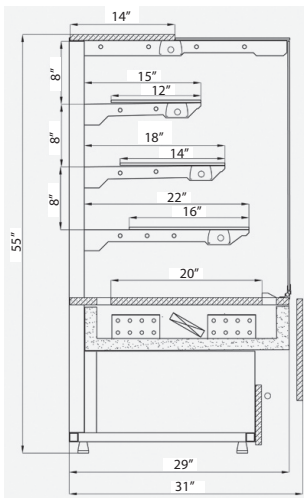

### Pastry

MODEL	DIMENSIONS	CAPACITY	VOLTAGE
<b>C 09 PN-W</b>	<b>L37" x D31" x H55"</b>	<b>1/3 HP</b>	<b>115V/12A/60Hz</b>
<b>C 13 PN-W</b>	<b>L53" x D31" x H55"</b>	<b>1/3 HP</b>	<b>115V/12A/60Hz</b>
<b>C 17 PN-W</b>	<b>L69" x D31" x H55"</b>	<b>1/2 HP</b>	<b>115V/15A/60Hz</b>

#### Standard:

- Forced-Air refrigeration system
- Curved front glass open from the top
- Glass shelf on the top
- Light under each shelf
- Temperature control with thermometer
- Automatic defrosting
- Automatic condensation disposal
- Front window defogger
- Environment friendly R 134
- Humidity control system

#### Optional:

- Self contained
- Cases only (no compressor)
- Exterior colours available

#### Environment:

- The equipment is designed to operate under normal environmental conditions being below 75° F/24 °C ambient, 55% Relative Humidity.

- All measurements are approximates
- Specification is subject to change without notice

